



Original paper

## Study of Pre-stressed Concrete Beam under Flexural Loading

Mohammad Torabi Yazdi<sup>1</sup>, Mohammad Norouzi Shavir<sup>2\*</sup>

<sup>1</sup> School of Civil Engineering, Sharif University of Technology, Tehran, Iran.

<sup>2</sup> School of Civil Engineering, College of Engineering, University of Tehran, Iran.

### ARTICLE INFO

#### Article history.

Received 2 December 2024

Accepted 9 January 2025

#### Keywords:

Pre-stressed Concrete

ABAQUS

Pressure Load

Tensile Load

### ABSTRACT

Today, saving energy in various fields has a special importance. Given the progresses made in the civil engineering, it can be mentioned in the optimal design of structures with the aim of using the minimum of material and human resources to achieve a maximum capacity of the structure. We can achieve more economic and even more beautiful design with designing and assigning the cross-section of the bridge as a changeable form due to the long length of some concrete bridge spans and thus the great number of changes in the internal forces of the cross-section. In this paper, pre-stressed transverse beams are modeled and optimized based on the principles and relations of the finite components. In this purpose, by using the results of a laboratory research, the mentioned beam is modeled in ABAQUS software and load variable in different beam is considered. For this aim, evaluate the effect of changing load of the tendons in the concrete beams performance and compared Pre-stressed concrete with normal concrete.



DOI: <https://doi.org/10.21859/jces.9159>

©2025 JCES All rights reserved

### 1. Introduction

Pre-stressed concrete is a method to overcome the weakness of concrete in tension. The pre-stressed concrete can be used for constructing the beams, base of the floors or bridges with a great span which cannot construct with reinforced concrete. Pre-stressed tendon (generally tensile steel cables) is used to create resistant loads. These resistant loads by creating a compressive stress cause the balance with tensile stress that they will appear on a concrete compressive member when it is under flexural loads. The process is performed by steel strings, sleeve and so on and it requires a special tool. The methods of pre-stressed of concrete are performed with the pre-stressed with pre-tensioned and the pre-stressed with post-tensioned. The steel bars are used in concrete in typical reinforced concrete [1]. The fib code outlined the service and the shear capacity of beams with providing more information about tensile stresses [2]. Cork (2015) investigated about the impact of FRP on pre-stressed concrete structures and the results showed that using FRP leads to improve and control the beam behavior [3]. Warenycia (2017) studied about the useful length of pre-stressed

tendons and the amount of the tension under the load, which showed that using the pre-stressed tendons lead to reduce the existing stress on the beam and on the other hand it strengthens the concrete beams against the tensile force [4]. Pereira et al., (2017) conducted a case study about the pre-stressed concrete beams in Brazil. The grouting within the tendons of pre-stressed are investigated and the results have shown that designed structure is able to bear the tensile load in a very reliable and safe condition [5]. In the present study, there rectangle concrete beams with tensile tendons with different diameters have been studied and the variation in the load, the beam has been examined and finally the results of different loading on concrete pre-stressed beams will be compared with normal beams.

### 2. Materials and Methods

Three beams with identical geometry were tested to assess the effect of shear span ratio to the depth in the tested capacity of the element. The ratio of shear span with the depth ratio ( $a/d$ ) for these tests, 3, 4 and 4.5 were considered and the names of the samples are considered as 1-4 beam

\*Corresponding author Email: [mohammadnorouzi98@ut.ac.ir](mailto:mohammadnorouzi98@ut.ac.ir)

respectively. The test was specifically designed to assess the shear- flexural interaction behavior on pre-stressed beams with self-compacting concrete. The beams have been designed such a way that have a shear failure instead of flexural failure. For this purpose, a great number amount of longitudinal reinforcements was placed at the cross-section ( $p = 0.023$ ) as well as a large number of compression reinforcing bars were placed at the top of its cross-section ( $p' = 0.023$ ) to allow the large replacement to cross- section and to yielding the tensile reinforcements partially both in the failure of the shear and concrete crushing. The beams were tested under two points loading effect, so that a steel beam was placed in the middle and the steel beam was symmetrically placed on the pre-stressed concrete beam and the load was transferred by two supports of the steel beam to the concrete beam. The concrete beam is a simple beam as well as the load is uniformly increased and after each 45KN, the test stopped for evaluating. The initial pre-stressed force in the cables was 124KN. Other features of the beam have been shown in Figure 1. The samples of beam were equipped by 8 linear differential variable transformers (LDVT) at the length of beam shear span. The LDVT situation changes in any sample. For example, Figure 2 shows the LDVT position for the PCD3 [6].

As seen in the Figure, the distance between the longitudinal reinforcement is 455 mm. The modeled beams in the application include the longitudinal and transverse reinforcement and as well as the pre-stressed tendons which their area is introduced in the software. Figure 2 shows the dimensions of the modeled beam in the software. The tensile tendons modeled in this paper are three and the diameter of the modeled reinforcements is 22 mm that are used at different points of the beam as Figure 1. Figure 4 shows the flexural load on the beam that is applied at two points on it. Finally, Figure 5 shows the mesh of the beam, longitudinal and tensile reinforcement.

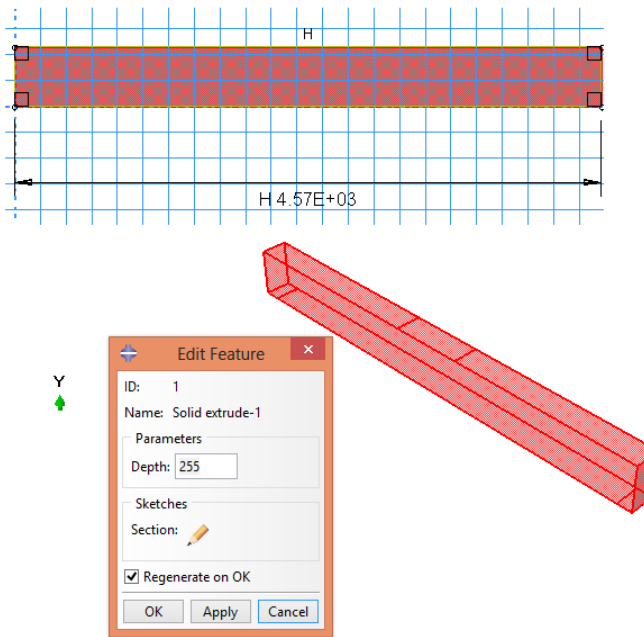

Fig 1. The cross-section and considered beam in Abaqus software.

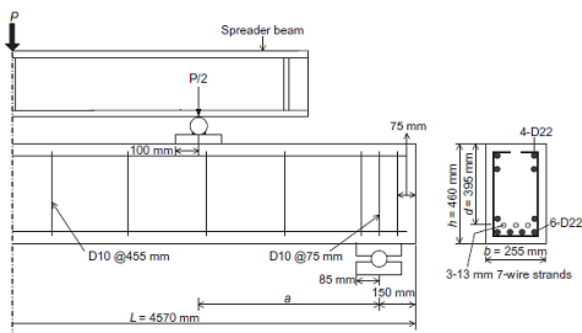

Fig 2. LDVT position for the PCD3 [6].

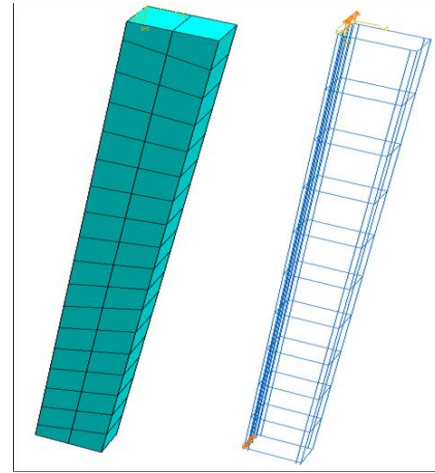

Fig 3. Mesh and modeling steps.

The results of tests showed that all samples have been broken as a form of shear, particularly with crushing concrete at a point between the loading place and nearest support. Figure 4 shows a break pattern for the PCD1 sample. In the Figures 5- 7 shows the graph of the load against the vertical displacement of the middle of the span. The first change of the slope in the displacement for all graphs is about 5 mm that this point shows the crack of the beam.

### 3. Validation

Leonardo et al., (2013) investigated about pre-stressed beams in the laboratory. The results of tests showed that all samples have been broken as a form of shear, particularly with crushing concrete at a point between the loading place and nearest support. Figure 4 shows a break pattern for the PCD1 sample. In the Figures 5- 7 shows the graph of the load against the vertical displacement of the middle of the span. The first change of the slope in the displacement for all graphs is about 5 mm that this point shows the crack of the beam [6].

In the present study, the constructed beams have been modeled in the laboratory by Abaqus software and it is close to the displacement loading graphs in the laboratory, however, in this study, after creating model, the typical beam has been modeled one time to determine what extent the use of pre-stressed beams can be effective on its performance. Figure 6 shows the graphs of displacement load for validated in the beams without pre-stressed tendon and pre-stressed beams. One of the important aim of this study is to validate this previous research and evaluated the capability of ABAQUS to model pre stress concrete.

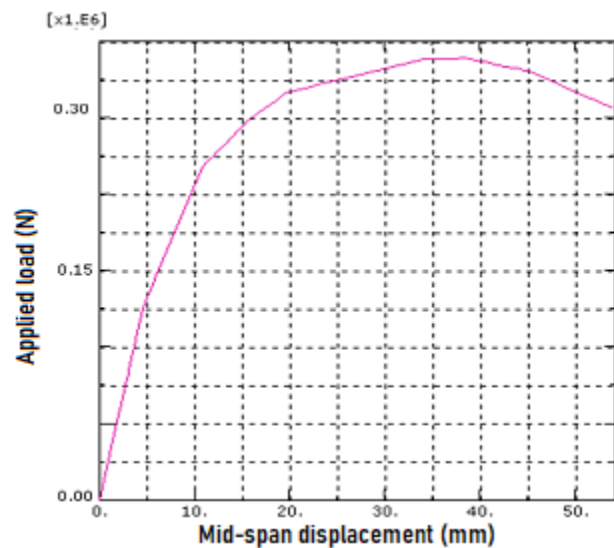

Fig 4. Load-displacement curve for considered beams in the research.

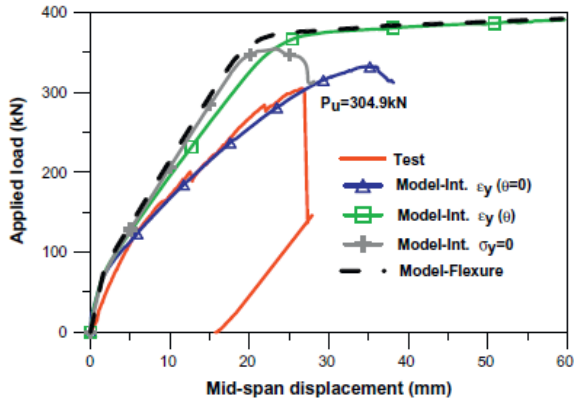

Fig 5. Load-displacement curve for considered beams in the research [6].

In this study, after validation of the present beam with paper of Leonardo et al., the pre-stressed concrete behavior has been studied under different loading. The variation in the loading as well as the comparison with the typical concrete is a new parameter which has not been seen in previous studies. As the study shows, only one rang of pre-stressed tendon has been used, therefore, to consider different elevation places of pre-stressed tendons and also adding one or two rows in the beam and evaluate its performance is a new subject that we will consider to study in this research. Therefore, firstly, new models and variables will be discussed and then, all results will be compared on some graphs in the results section. Table 1 represents the various models considered in the research.

Table 1. The models of the research.

Area of tendon under tension	Diameter of tendon	Rate of loading in the middle of beam	Row of tendon	Number of models
4	10	60	Tendon with 3 rows	3
4	10	200	Tendon with 3 rows	4
...	...	60	Without tendon	1
...	...	200	Without tendon	2

Primarily, considered models in this research include the change in the magnitude of load for normal concrete without tendon in which models 1 and 2 will be discussed. In the next step, the study of change will be investigated in the load of the beam by fixing the number of tendons in a

row in models 3 and 4, the variable rate of load will be considered (60kN, 200kN).

4. Results

In this section of research, the graphs of displacement and the tension created in the beam are brought respectively as well as the load of displacement graphs are considered at the end of the research and the rate of change in the reinforcing bars, the rate of change in the load of the tendons will be studied and compared to each other. Also in the discussion section, the results of maximum displacement and tension are compared in all the models. The rate of flexural loads created on the beams has been 60kN and 200kN that its results will be discussed for beam without pre-stressed tendons and beam with tendons. The rate of applied displacement in the beam is about 200mm which this increase of load in the rate of displacement has not changed very much, but the rate of the tension in the beam increase about 2.25 times. In the following, the use of three tensional tendons are investigated in 396 mm of the width of the beam and it can be seen that the rate of displacement reaches to 50mm that indicates a considerable rate of beam displacement which has been reduced by the effect of flexural load. But they could not reduce the displacement of the beam by the 200kN loading of the tendons, but the tension rate has somewhat decreased. It can be said that in low loading, the tendons reduce the displacement partially with the help of longitudinal reinforcements of the beam, but in the high loading, the concrete deforms and the tendons roles are less, because in the first place, the load is applied at the top of the beam and then the tendons can affect in the reduction of deforming with the help of concrete, but the total tension created has been reduced in the beam.

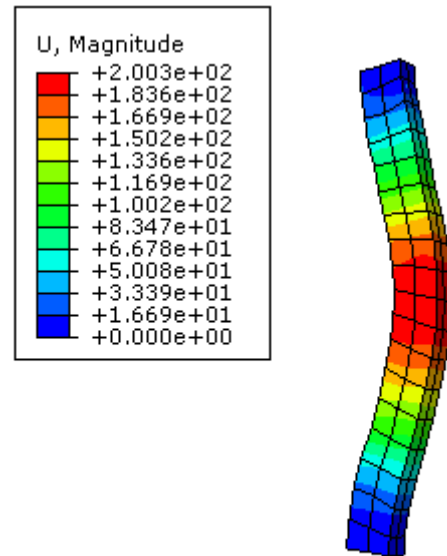

Fig 6. The results for model 1 (tensile tendon -60kN load).

As it can be seen in Figure 6 to 13 , for the sample 1 to 4 with the ratio of the length of the shear span to the cross-section depth that is equal to 3, does not show the bars yielding test before breaking cross-section. In addition of this issue, after reaching the cross-section to the peak load, the sudden breaking occurs and the diametrical cracks will be rapidly extended. Also, as it can be seen in Figures, the bearable load by the beam is more in samples 1 and 2 and it is less or samples 3 and 4. This case indicates the interaction impact of the bending and shear and its impact on the reduction of cross-section capacity in greater load (200kN).

The displacement rate for the beam and created force of this displacement in the pre-stressed tendons has been shown in the Figure 8.

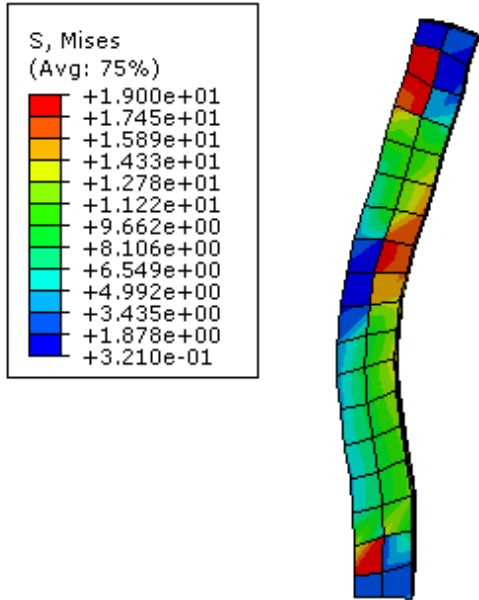

Fig 7. The results for model 1 (tensile tendon -60kN load).

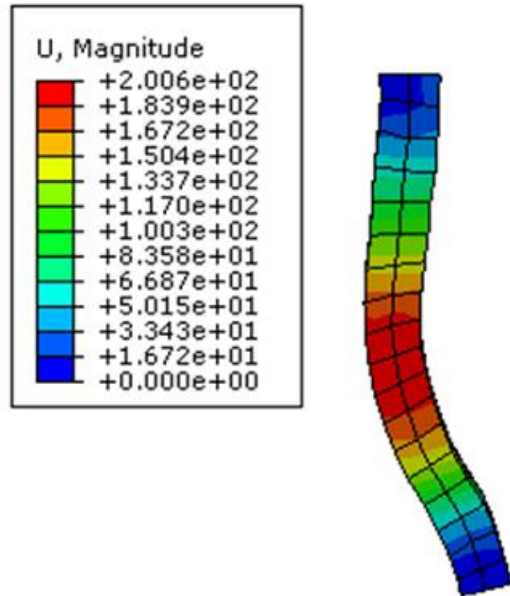

Fig 10. The results for model 3 (without tensile tendon -60kN load).

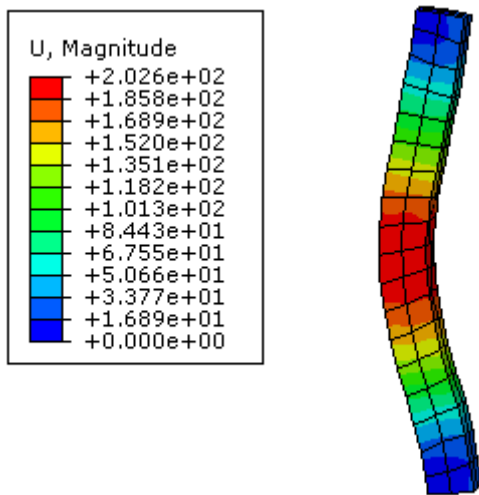

Fig 8. The results for model 2 (tensile tendon -200kN load).

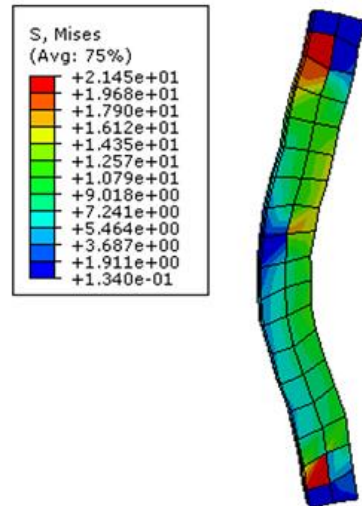

Fig 11. The results for model 3 (without tensile tendon -60kN load).

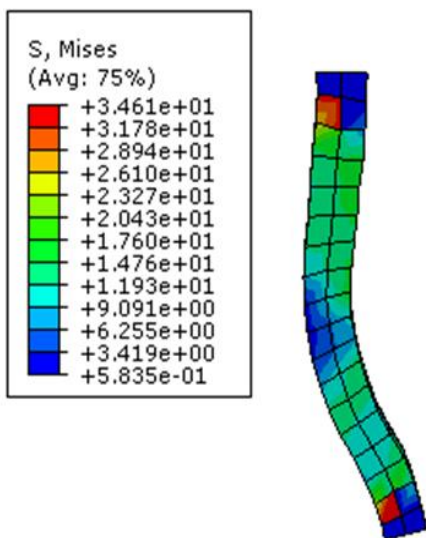

Fig 9. The results of the model 2 (tensile tendon -200kN load).

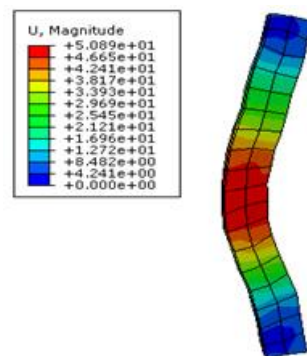

Fig 12. The results for model 4 (without tensile tendon -200kN load).

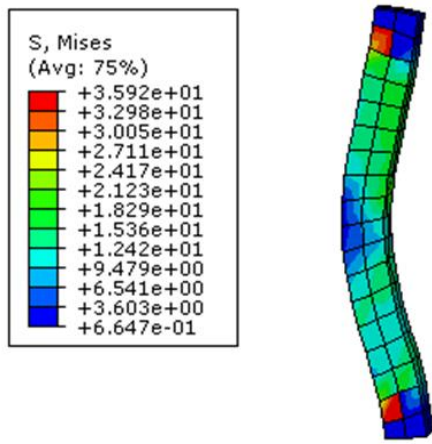

Fig 13. The results for model 4 (without tensile tendon–200kN load).

In the following, the rate of pre-stressed created force in the tendons indicates its importance in the use of tendon which leads to more tensile tension in tensile tendons and increasing the resistance of the concrete in the tension with taking this tensile force. Therefore, the tensile loading in beam has been embedded as the displacement at the end points of tendons to determine how they will act with increasing load. The graphs of force and displacement created in tendons due to the tensile loading are drawn in Figure 14 and for normal concrete shows in Figure 15. The load change is discussed in order to evaluate the effect of using pre stress concrete and in the following, the force-displacement graphs are drawn in this figure. Using tendon leads to reduce the displacement.

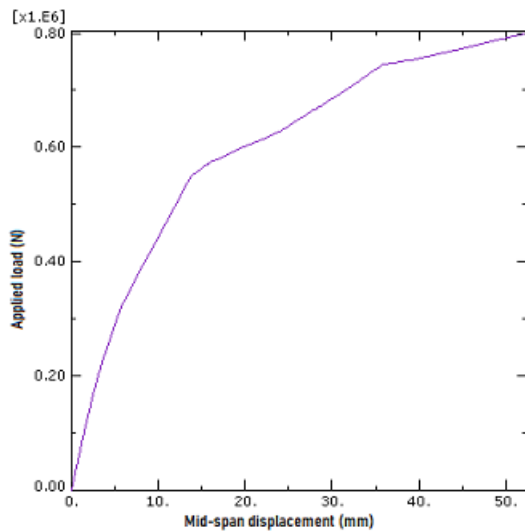

Fig 14. The results of model 1 (load-displacement with the tensile tendon).

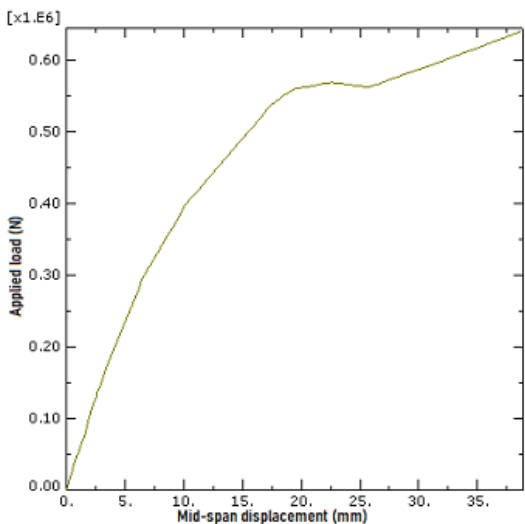

Fig 15. The results of model 3 (load-displacement).

5. Conclusions

Despite a great number of researches that have been taken place in connection with the numeral study of the finite components of the members’ behavior in the typical reinforced concrete, pre-stressed members, but a few studies have been relatively conducted in the field of pre-stressed concrete members and modeling the finite members of it. In the current study to investigate the behavior of a real pre-stressed member and also for study of the accuracy of modeling method and the researches’ result, modeling and analysis of a composite and pre-stressed girder were conducted based on a laboratory study. The results of finite members’ analysis and theoretical analyzes of the manual calculations performed in the present study compared with experimental results of the considered sample and the efficiency and accuracy of the finite component rate has been evaluated in the proposed model. Acceptable compliance of the obtained results with the of laboratory results indicates the application of the proposed finite members model.

Due to that now many of the high span bridges have been designed and constructed using the technique of pre-stressed and due to significant changes of loading regulation and seism analysis methods in recent years, most of these bridges need the reinforcement and strengthening. Therefore, there is the need of the reliable models for nonlinear analysis that in this research has been studied, the result of this paper shows:

- ✓ Increasing the pressure load led to increase the beam displacement and also deformation.
- ✓ The stresses entered on the panel have reached to about 1.61 times when the load reached to 200kN.
- ✓ The stresses entered on the beam have decreased to about 1.03 times when using pre stress beam at 60kN.

Conflict of interest

There is not conflict of interest.

References

[1] Sargious, M., and Tadros, G. (1974). Stresses and Forces in Deep Beams Prestressed with Straight Cables. *PCI Journal*, 19(4), 86-99. <https://doi.org/10.15554/pci.07011974.86.99>

[2] Warenycia, K., Diaz-Arancibia, M., and Okumus, P. (2017). Effects of confinement and concrete nonlinearity on transfer length of prestress in concrete. *Structures*, 11, 11-21. <https://doi.org/10.1016/j.istruc.2017.04.002>

[3] Fib Model Code for Concrete Structures. (2010). International Federation for Structural Concrete.

[4] Cork, R., Foote, J., de Waal, L., Nguyen, V. T., and Fernando, D. (2015). FRP strengthening of 60 year old pre-stressed concrete bridge deck units. *International Conference on Performance-based and Life-cycle Structural Engineering*, 1228-1237. <https://doi.org/10.14264/uql.2016.405>

[5] Pereira, S. S. R., M. D. C. Magalhaes, and H. Gazzinelli. (2017). an alternative technique to the demolition of a prestressed concrete box-girder bridge: (A case study). *Case Studies in Construction Materials*, 6, 192-197. <https://doi.org/10.1016/j.cscm.2017.03.003>

[6] Massone, L. M., Gotschlich, N. J., Kang, T. H. K., and Hong, S. G. (2013). Shear–flexural interaction for prestressed self-consolidating concrete beams. *Engineering Structures*, 56, 1464-1473. <https://doi.org/10.1016/j.engstruct.2013.07.019>



This is an open-access article under a [Creative Commons Attribution 4.0 International License](https://creativecommons.org/licenses/by/4.0/).